

Ziegler

Redefine Innovative Metering

Switched-Mode Power Supplies

Primary Switched Power Supply. (PS3 24XX)

© Ziegler Instruments Order No. Ziegler SMPS.03_PS3-24VDC-EI.R0-920513-31-2013-EN



Thank you for having chosen one of our products for your work. We are certain that it will give the utmost satisfaction and be a notable help on the job.

General Description

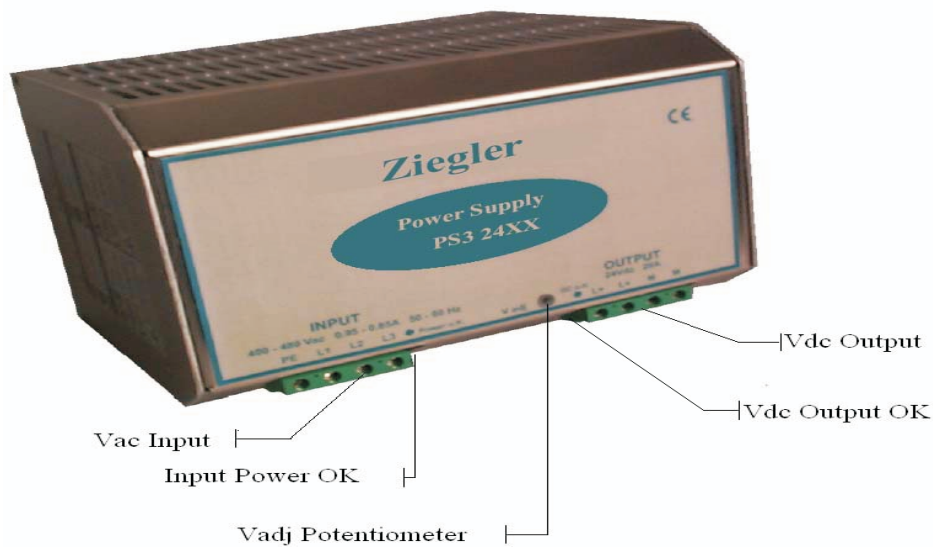

Instructions Manual

Application

The **Ziegler** power supply PS3 24XX can be used in areas from extreme industrial environment, and complies with the latest technical standard. Before begin the operations of installation consult the manual.

Mains Characteristic

- Protection against short circuit and overload.
- Primary input: 400 - 480 Vac.
- Environmental condition/relevant aproval: IEC/EN 60950, UL 1950
- Single Output 24Vdc 30 A / 40 A
- Mounting DIN Rail
- Limits for harmonic current EN61000-3-2

Rail mounting

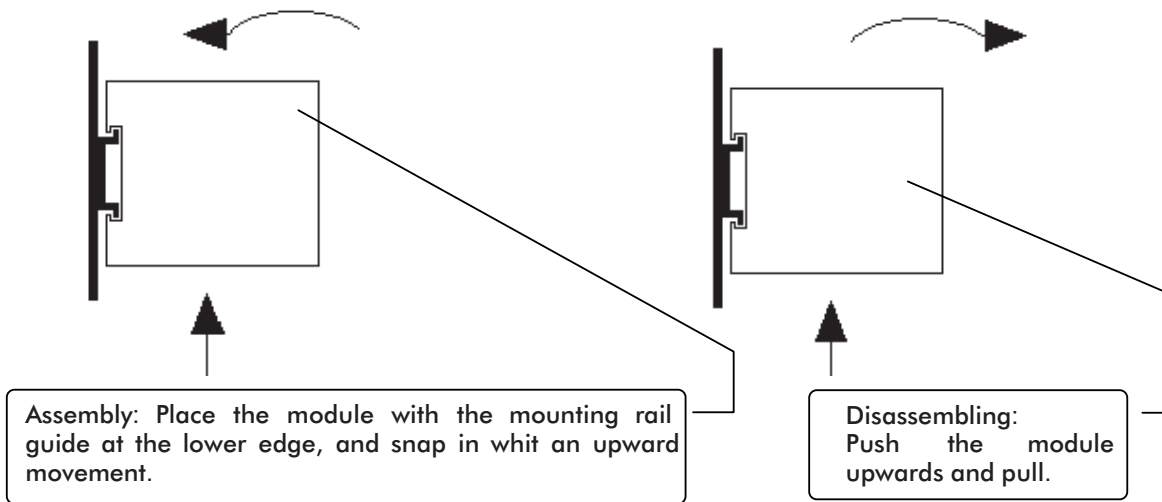

Other modules must have a minimum vertical distance of 10 cm to this power supply in order to guarantee sufficient auto convection.

Use and Connections

Caution: Switch off the system before connecting the module. Never work on the machine when it is live.

Cable connection

The following cable cross-sections may be used:

At the Input: 0.2÷2.5 mm² rigid / flexible

At the Output: 0.2÷2.5 mm² rigid / flexible

Strip the connection ends: 7mm

Input: The input connection is made by the screw connections L1, L2, L3, PE[⊕]. The power OK Led control, signalises that the device is functioning ON.

System connections:

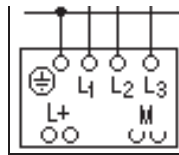

Output: Output voltage 24 Vdc is made via the L+)+(, M)-(. The red led ON signalises the correct output power. The output voltage can be adjusted from the potentiometer place on the front panel of the module. When the Red Led switch on/off, the device is in overload range or in short circuit protection. When the Green Led is off the power supply has been interrupted.

Protection

On the primary side: the device is equipped with an internally fused 6,3 A. If the internal fuse is activated, it is most probable that there is a fault in the device. If it happens, the device must be checked in the factory.
Caution: Double Pole/ Neutral Fusing.

On the secondary side: The device is electrically protected against short circuits and overload.

Parallel Mode

There are no restrictions for the parallel connection of 2 devices, the output current will be $I_n \times n$ (two devices)



Caution: The output Voltage must be adjusted at the same value.

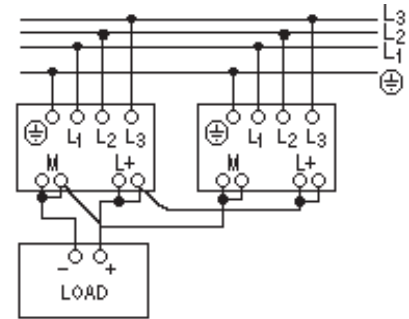

Characteristic Curves

Short circuit and overload

The output of the device is electrically protected against overload and short circuit. At nominal voltage the device can supply 1.1 the nominal Current without switching off. In the case of higher overload, the operating point traces the curve illustrated in figure. As the overload increases, the output voltage is reduced until zero.

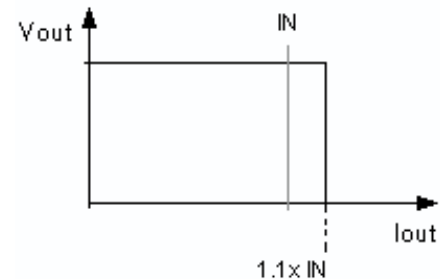

Thermal behaviour

The device supplies the nominal output current at ambient temperature of up to 50°C. For ambient temperature of over 50°C, the output current must be reduced by 1% per °C increase in temperature.

Standards and Certification

Electrical safety

Electrical safety is ensured by assembling the devices in accordance with EN 60950 / VDE 0805. The device is certified in accordance with EN 60950 / VDE 0805, UL1950, CSA 20.2 N° 950. The device must be installed in accordance with EN 60950. The device must have a suitable isolating facility outside the power supply unit, via which can be switched to idle.

General Standard

Compliance with EN 61000-3-2 (line harmonic current),
Immunity in accordance with EN 50082-2, level 4, class B
Radio interference suppression in accordance with EN 55011 class B (industrial areas)

Features

Input Data

Nominal Input Voltage (3 x Vac)	400 – 480 Vac
Input voltage range	360÷530 Vac
Inrush Current) $I_{n - In}$ ($\leq 10 \leq 5$ msec.
Frequency	47 ÷ 63 Hz
Input Current)Nominal input Voltage(1.7 – 1.5 A
Internal Fuse	6.3 A
External Fuse)recommended(Fast 6.3A

Output Data

Output Voltage / Nominal Current	24 Vdc /)30A / 40A(
Adjustment range) V_{adj} (22 ÷ 26 Vdc
Switching on after applying mains voltage	2,5 sec. Max.
Start up with capacitive load)1 15/230 Vac($\leq 30.000 \mu F$
Current max.	$1.1 \times I_N \pm 5\%$
Residual Ripple	$\leq 100 mV_{pp}$
Minimum Load	No
Efficiency	$\geq 86\%$
Short-circuit protection	Yes
Over Load protection	Yes
Over Voltage Output protection	Yes
Parallel connection	Yes

Climatic Data

Ambient Temperature)operation(-10 ÷ +50 °C
Ambient Temperature)Storage(-25 ÷ +85 °C
Humidity; no moisture condensation	95 % 25°C

General Data

Isolation Voltage)Input/ output(3000 Vac
Degree of protection	IP 20
Protection class	I with PE connected
Dimension (w-h-d)	250 x 150x 160
Weight	4,2 Kg approx
In according to EMC 89/336/EEC and Low voltage 93/68/EEC	

ZIEGLER INSTRUMENTS

Schnepfenreuther Weg 6, D-90425 Nürnberg, Germany.

TEL. | (+49)(911) 38 492 45 E-MAIL | info@ziegler-instruments.com
 FAX. | (+49)(911) 32 26 212 WEBSITE | www.ziegler-instruments.com



Ziegler

Redefine Innovative Metering